



South African Quilters' Guild

Promoting Quiltmaking in South Africa

National Quilting Day Quilt South Africa 2025

Star block

By Bettie van Zyl



Detail from The Roux Coverlet

This year the SAQG highlights our South African quilt heritage with a block pattern from a quilt discovered by Bettie van Zyl, quilt historian and SAQG Heritage portfolio.

The Roux Coverlet



This wonderful quilt crossed Bettie's path in January 2025. It is owned by Paul and Belinda Roux who live in Prince Albert.

Size: Length 2m x Width 1,50m

Age: 150 years

Style: Victorian- William Morris Era circa 1850

History

The quilt was most probably made by a Great Aunt, Alida Jacoba Bartmann, who attended Huguenote Kollege (Paarl), during the late 1800's. It is believed that American missionaries introduced the students to quilting and taught them the techniques used to make this quilt. She later passed it on to her nephew, Jacobus Petrus Roux, who attended Worcester School for the Deaf. The quilt is still in excellent condition.

Technique

This is an example of a coverlet (a “deken” in Afrikaans), made of two layers only and hand quilted in vertical lines that are 10cm apart. The front as well as the back are made of satin and sateen fabrics. The Six Point Star in the centre is appliqued on a background and surrounded by English paper pieced (EPP) Hexagon Flowers. Each flower has a centre hexagon where embroidered motifs from old handkerchiefs were cleverly used.

Design

The quilt design consists of a central Six Point Star, surrounded by Hexagon Flowers, carefully laid out with an diagonal cross design with alternating rows of light and dark hexagon flowers, to form a very interesting overall layout. Note how some of the fabric for the hexagon flowers have been fussy cut to further enhance the design.

Finishing

The quilt has turned in edges and was finished with a running stitch, typical of quilts from that era.

Historian: Bettie Laslap²⁰²⁵



Six Point Star detail

The Star Block

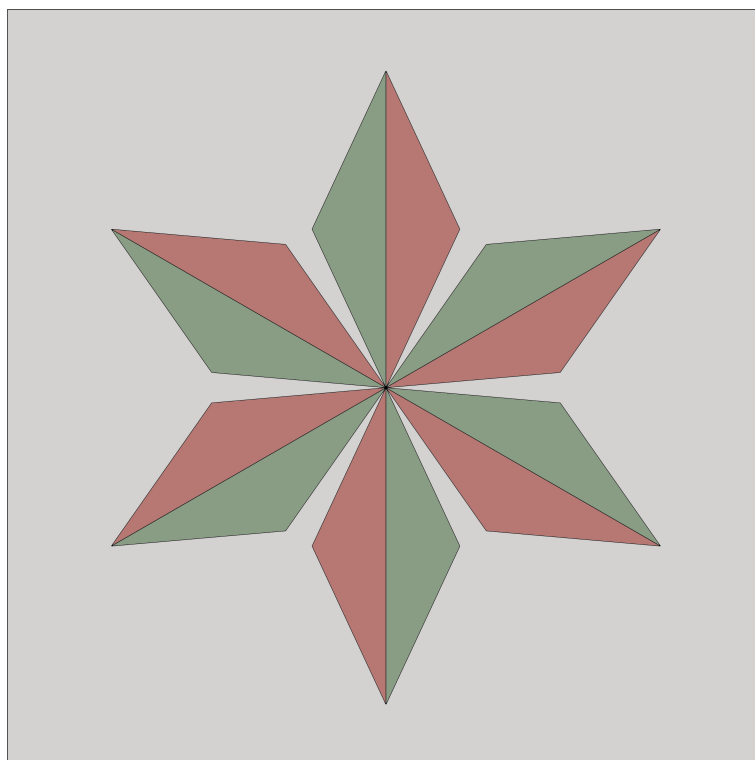

The Star Block is an applique project which can be made by hand or machine. Templates and instructions are provided for 2 different completed block sizes, a 15" x 15" block and a 10" x 10" block.

Fabric requirements

	15" Block	10" Block
Background fabric	(1) 15½" x 15½"	(1) 10½" x 10½"
Fabric 1 (pink/light)	(6) 2¼" x 8" strips	(6) 1¾" x 5½"
Fabric 2 (green/medium)	(6) 2¼" x 8" strips	(6) 1¾" x 5½"

Making the block

1. Align Fabric 1 and Fabric 2 strips, right sides together, and secure with pins.
2. Sew together on the long side of the strips with a ¼" seam allowance by hand or machine. If sewing by machine, chain-piece the strips (feeding one unit after another without cutting the joining threads) to speed up the process.
3. Set the stitches by pressing the sewn lines to settle the stitches into the fabric and press the seams open.

4. Trace the diamond template on applique paper (without the ¼" seam allowance). On the wrong side of the fabric, align the midline of the template with the sewn line. Press to adhere. Cut out the diamond shaped star point unit. Repeat to make (6) star point units.
5. Arrange the star points on the background fabric block as shown in the diagram. Press to secure in position.
6. The Star Block can now be completed by appliqueing the units by hand or machine using a stitch of your choice.

Alternative method

If you prefer English Paper Piecing (EPP) to raw edge applique, follow steps 1-3 as above.

4. *Trace the diamond template on freezer paper (without the ¼" seam allowance). On the wrong side of the fabric, align the midline of the template with the sewn line. Press to adhere. Cut the fabric using the template as a guide, adding a scant ¼" around the edges. Repeat to make (6) star point units. Fold the seams over the template. (Use normal paper if freezer paper is not available.)*
5. *Arrange the star points on the background fabric block as shown in the diagram. Pin to secure in position.*
6. *The Star Block can now be completed by appliqueing the units by hand on the background fabric.*

We hope you'll enjoy making this pattern.
Please share photos of your blocks on our socials. We would love to see how you interpret this quilt block, 150 years later.

*Instagram: @quiltsouthafrica #quiltsouthafrica2025 #thestarblock
Facebook: SouthAfricanQuiltersGuild*

A special thanks to the Roux family for sharing this beautiful work of art with us and for preserving it with such care over the years.

If you own a piece of quilting history or know of hidden gems like this quilt, please let us know. We treasure our quilting history and would love to share them with fellow quilters.

Template for 15" Star Block

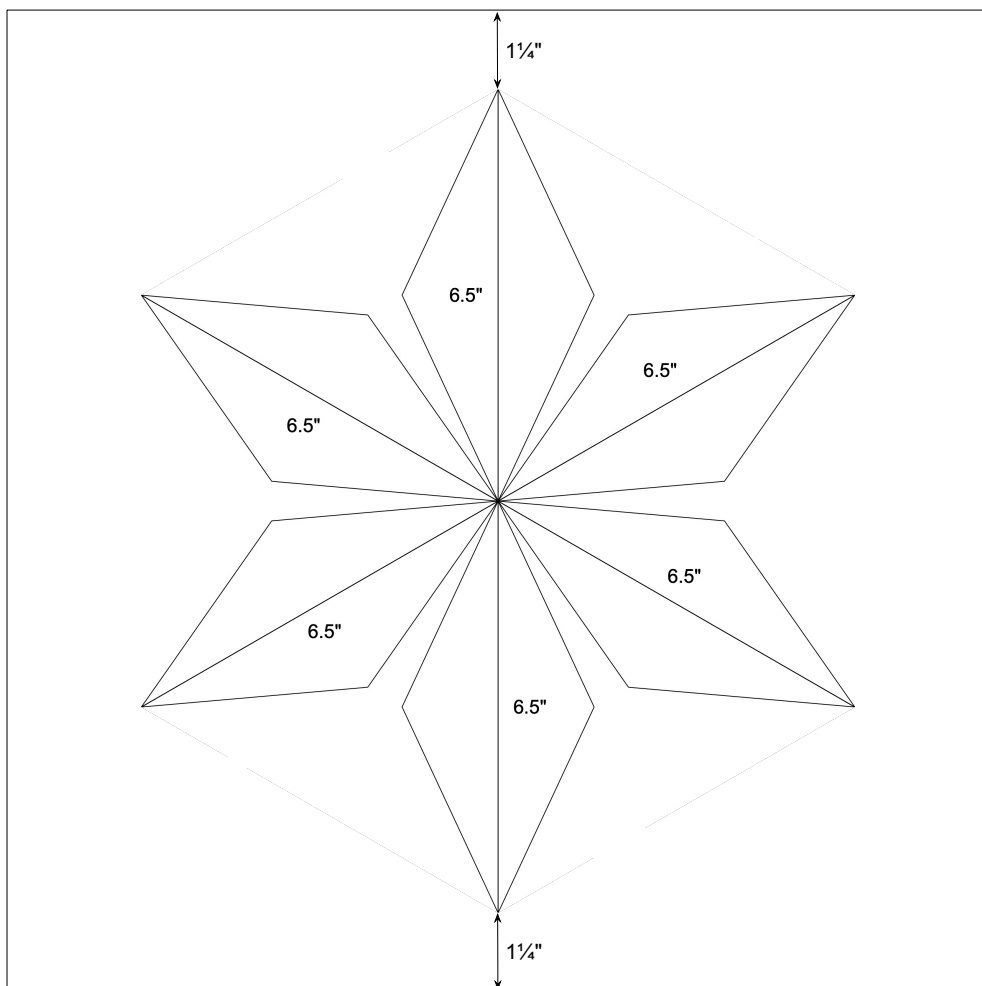
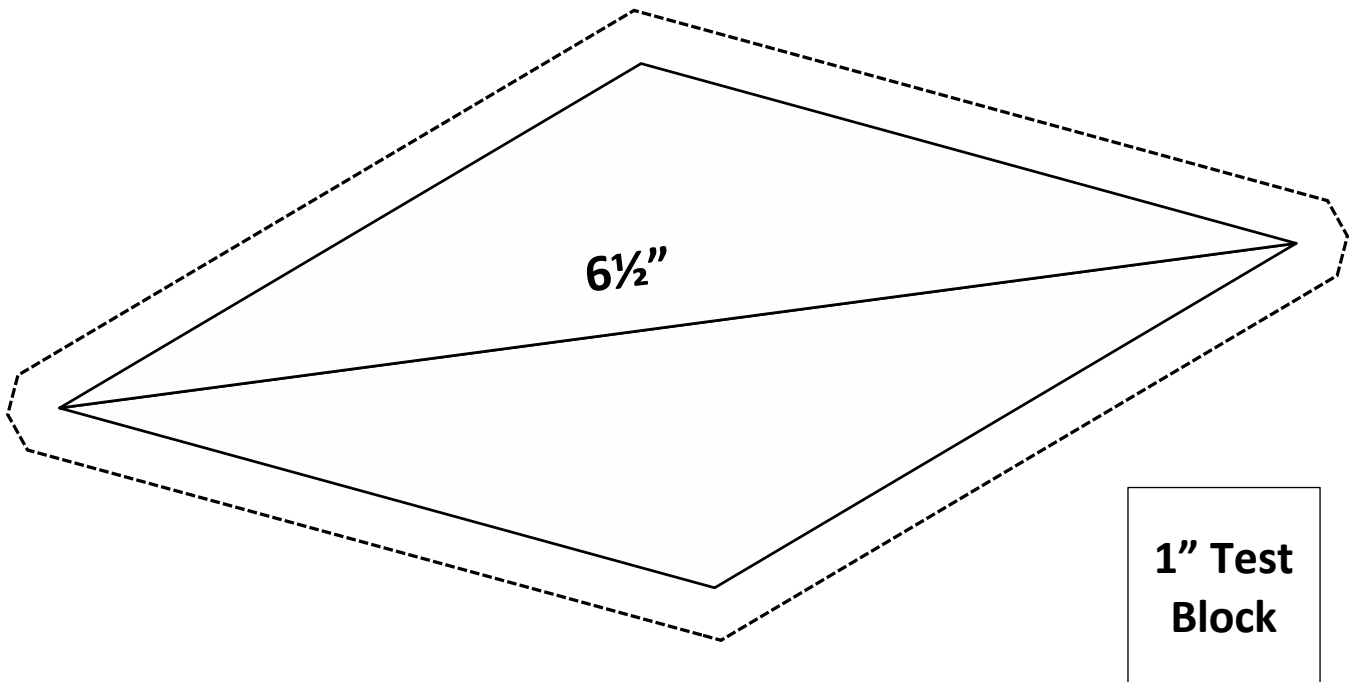

Template for 10" Star Block

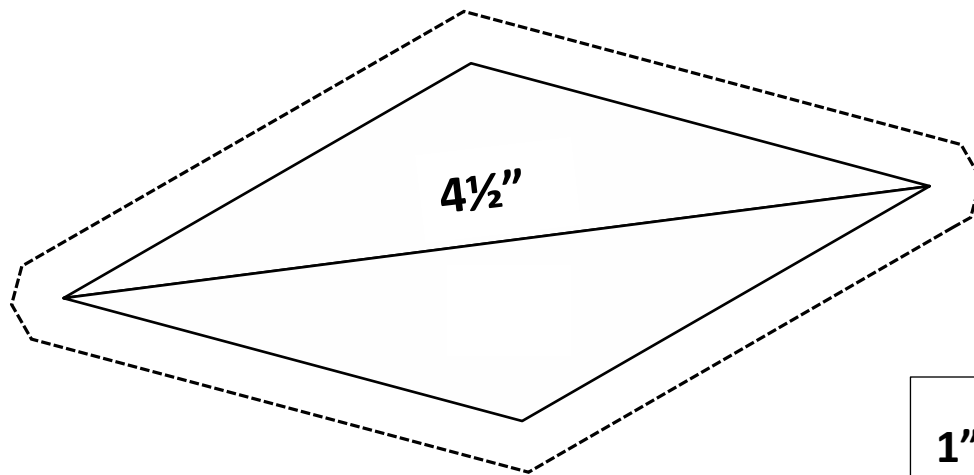

**1" Test
Block**

